



Technical Information

Partially filled stationary flow measurement

Calibrated measuring channel for backflow-free
flow measurement of waste water in open
channels or open channel pipes

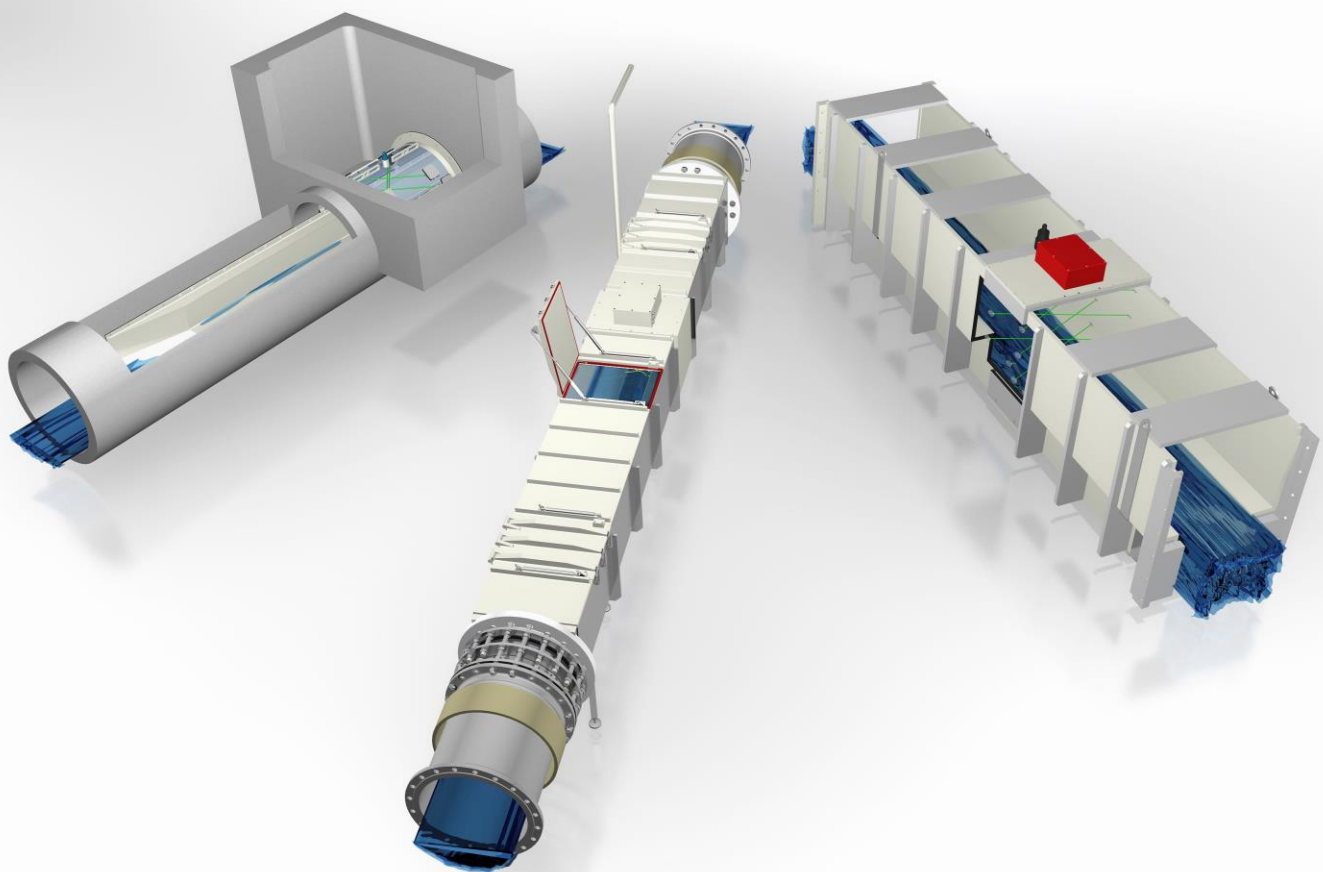

Table of Contents

Fields of application	3
Success characteristics	4
Technical structure	5
Measuring princip of the ultrasonic transit time difference	5
Channel shape, measurement of very small quantities and large measuring range	6
Adaptation/integration in existing buildings	7
Pros	9
Controllability	9
Reliability	10
Maintainability	10
Technical Specifications	11
Dimensioning	12
Theoretical lengths with average flow conditions	13
Dimensions transducer	13
Contact details	14

Fields of application

The need for cost accounting based on the polluter's costs is also increasing in the wastewater sector. The STEBATEC measuring system offers significant advantages to stationary, partially filled flow measurement, especially in view of the increasing demands on precise measuring and control systems:

- Quantity measurement in municipal wastewater associations
- Waste water discharge control for industrial plants
- Measurement of drainage water
- Mining and process water measurements in mining and tunnelling
- Cost accounting measurement
- Foreign water measurement
- rainwater measurement

Success characteristics

The partially filled stationary flow measurement has advantages during operation as well as during project planning and installation.

- Guaranteed and controllable measurement accuracy >99
- Self-calibrated measuring section
- Reliable, very difficult to manipulate and influence by solids, deposits or external influences
- Also works in case of backwater
- Maintenance and cleaning is easy because the unit is open at the top or easily accessible via maintenance openings.
- Backwater protection, emergency overflow
- Long service life - no wear parts
- Fits most existing buildings - no conversion necessary
- Large measuring range due to individually adaptable channel shape
- Installation possible without water diversion
- Installation usually possible in 1 day

Technical structure

Measuring principle of the ultrasonic transit time difference

Ultrasonic flowmeters measure the velocity of a flowing medium using acoustic waves. In simple terms, two boats crossing a river diagonally on the same line, one in the direction of flow and the other against the flow. The boat, which moves in the direction of current, needs a much shorter time to reach the opposite shore. The same applies to ultrasonic waves. A sound wave propagates faster in the flow direction of the measuring medium than the sound wave in the opposite direction.

The running times are measured continuously. The transit time difference of the two ultrasonic waves is therefore directly proportional to the mean flow velocity. The flow volume per unit of time is the result of the mean flow velocity multiplied by the respective pipe or duct cross-section.

Acoustic flow measurement offers some advantages over other measurement methods. The measurement is largely independent of the properties of the media used, such as electrical conductivity, density, temperature and viscosity. The absence of moving mechanical parts reduces maintenance and there is no pressure loss due to cross-section constriction. A wide measuring range is another positive feature of this method.

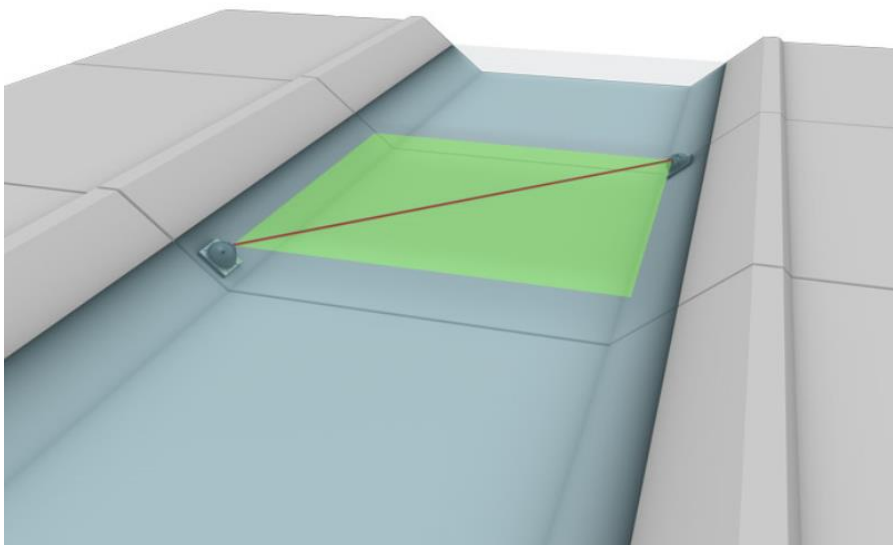

Channel shape, measurement of small quantities and large measuring range

Because flow meters often cannot measure low water levels, the precise measurement of very small quantities in wastewater flow measurement technology is generally considered a challenge. The purpose of STEBATEC's adaptable channel shape is therefore to provide a device for measuring flow rates in partially filled (open) sections, e.g. channels, but also in closed sections, e.g. pipes, even with (very) low discharge. Thanks to the "dry weather channel" on the partially filled stationary flow measurement system, water level and flow velocity remain measurable even in these cases.

In addition, the rain weather channel can also be dimensioned individually, so that the cross section of the unit can be adapted to the amount of water produced, resulting in optimum measuring conditions.

The right-angled shape was chosen to allow the sensors to be arranged close to each other and thus ensure a deep view of the flow profile.

Adaptation/integration in existing buildings

The partially filled stationary flow measurement was designed for integration into existing structures. Not only can the channel shape be adapted to the amount of water produced, but various adapters are also available for connection to the existing infrastructure.

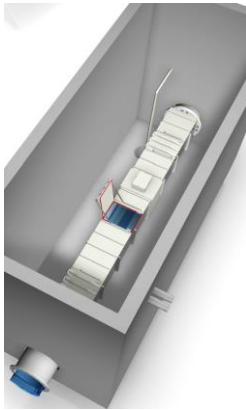

Example: Connection to a closed pipeline (dry installation with maintenance opening)

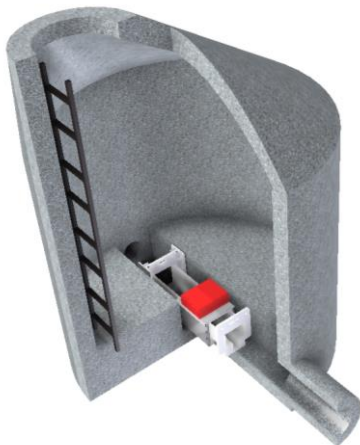

Example: Installation in a circular sewer shaft

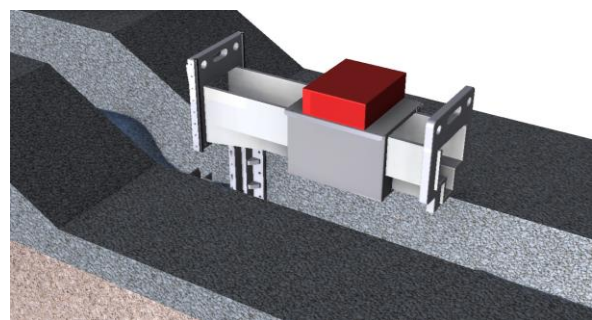
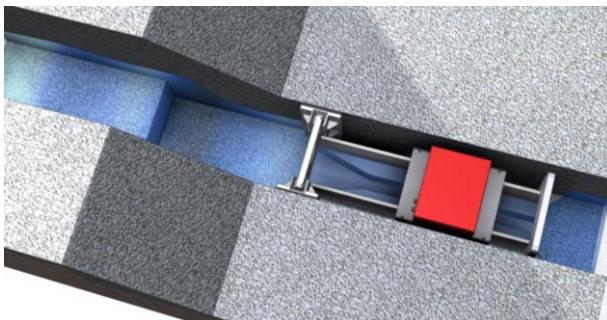

Example connection in rectangular duct with slide plate adapter. Assembly / Disassembly

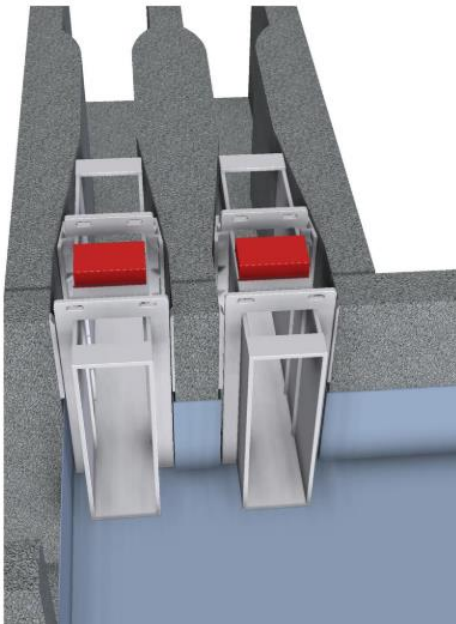

Retrofitting in the Venturi channel

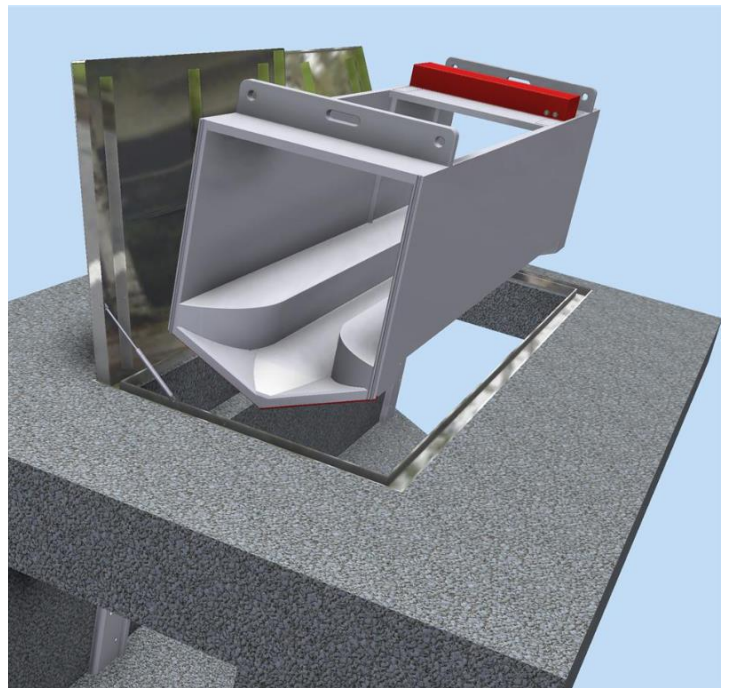

Installation in rectangular duct with minimal loss of cross-section.

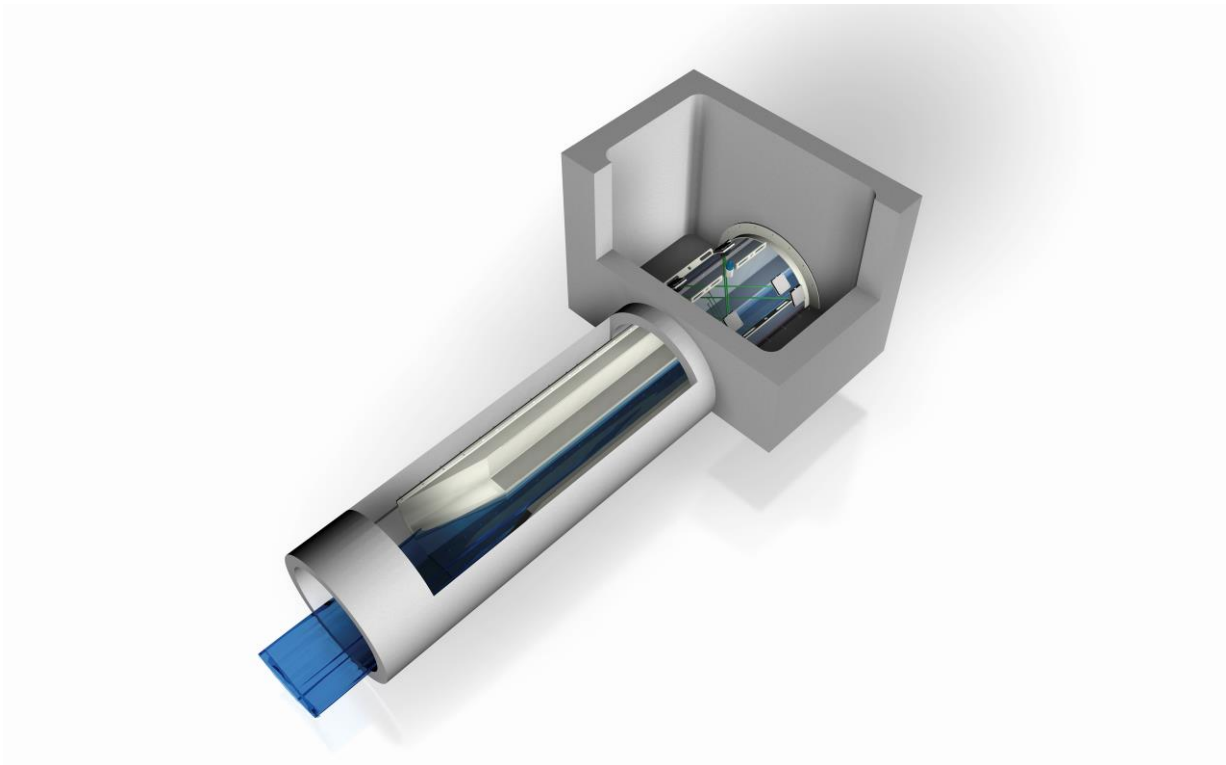

Example of "Inline" construction for sewers >1200mm

The built-in dry weather channel can be seen, which is single or double depending on the amount of water produced.

In large pipes and for further optimization of the measuring accuracy, additional runtime sensors are installed in the upper measuring cross section, which precisely measure the flow velocity when the channel is full.

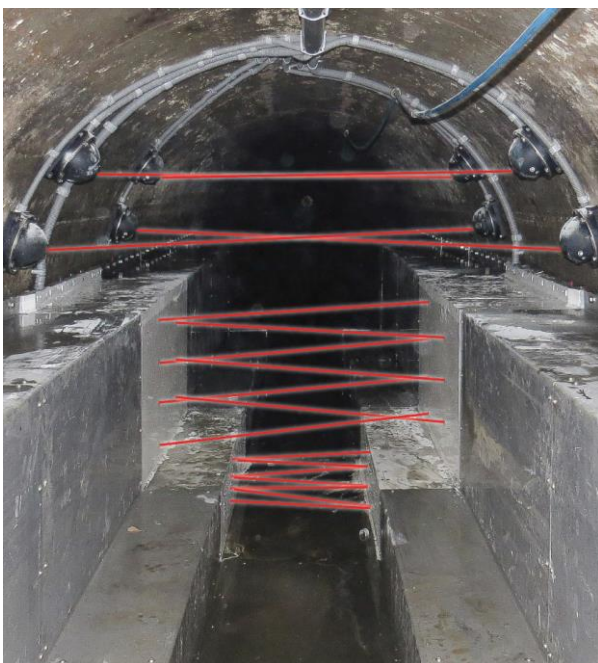

Pros

Partially filled stationary flow measurement with guaranteed and controllable precision is based on three principles:

Controllability

The partially filled stationary flow measurement is open at the top or accessible via maintenance openings, so that the measuring accuracy can be easily verified manually with a measuring rod and Q/H curve. However, the effective accuracy control takes place in our own calibration stand / hydraulic laboratory, where the systems are tested and calibrated under practical conditions with a reference measuring system.

With every measuring and control system, the effective measuring accuracy is defined and guaranteed at the location used.



Reliability

Local conditions such as hydraulics, channel roughness and channel slope do not influence the measuring accuracy, because specific hydraulic conditions are created by using the calibrated flume. In combination with sensors, which are difficult to manipulate due to solids and deposits, this creates optimum measuring conditions.

Maintainability

Long-term function and precision also depend on maintenance. Ease of maintenance is therefore an important component of the systems. Structure and arrangement are planned together with the customer and adapted to his needs and technical aids.

Technical Specifications

Pipe wall material:	Polypropylen (PP)
protection class:	IP 68
Ex-certification:	ATEX II 2GD EEX de, Verdraht. EEx e
Gasket material:	EPDM
temperature range:	0 – 80 °C
pH range:	6 – 9

dimensioning

The dimensioning is based on the hydraulic key data. The width of the dry weather channel should be selected so that a minimum level of 3cm (for nominal diameters <500mm), of 10cm (for nominal diameters <1000mm) is achieved for the smallest discharge value to be measured, on request (for nominal diameters $\geq 1000\text{mm}$). In wastewater applications, however, the dry weather channel is not dimensioned narrower than 10cm - if the minimum level cannot be maintained for this channel width, the system can be equipped with a threshold on the discharge side.

The overall height of the dry weather gutter is dimensioned with sufficient reserve (e.g. +20%) so that the discharge quantities do not overflow the dry weather gutter on dry weather days. The flow capacity of the rainwater channel located above the dry weather gutter is correspondingly large so that the measuring channel has no limiting effect in the overall system.

Calculation basis:

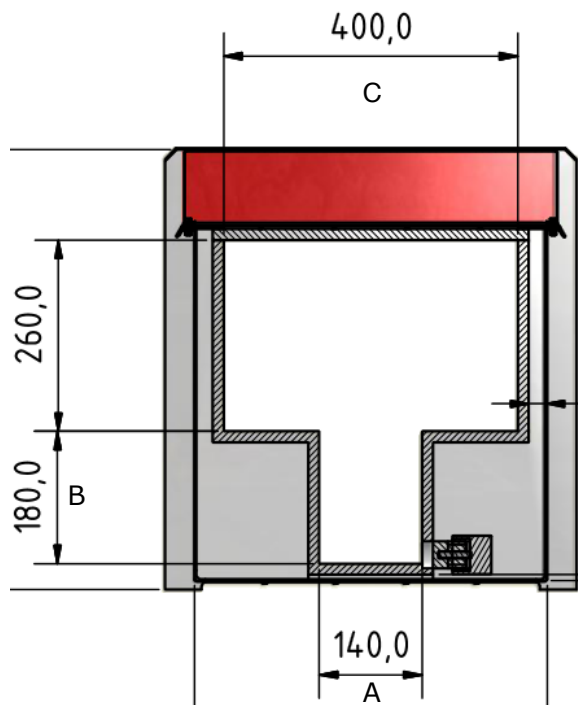

Example dimensioning using the example on the left

140mm Dry weather gutter width = Q_{\min} : 2.5 l/s

180mm Dry weather gutter height = Q_{twmax} : 40 l/s

260 x 400mm Rainwater gutter = Q_{rain} 150 l/s

Q_{\max} = 190 l/s

Q_{\min} ($H > 3 \text{ cm}$) = Width of the dry weather gutter (A)

$Q_{\text{twmax}} \times 1,2$ = Height of dry weather gutter (B)

Q_{Rain} = Rainwater channel volume (C)

Theoretical lengths with average flow conditions

The theoretical length is directly related to the encoder width/nominal size and normally amounts to approx. 6x the system nominal width. In case of steep gradients and turbulent flow conditions, the systems are built longer (<10xNW) depending on the project.

Dimensions transducer

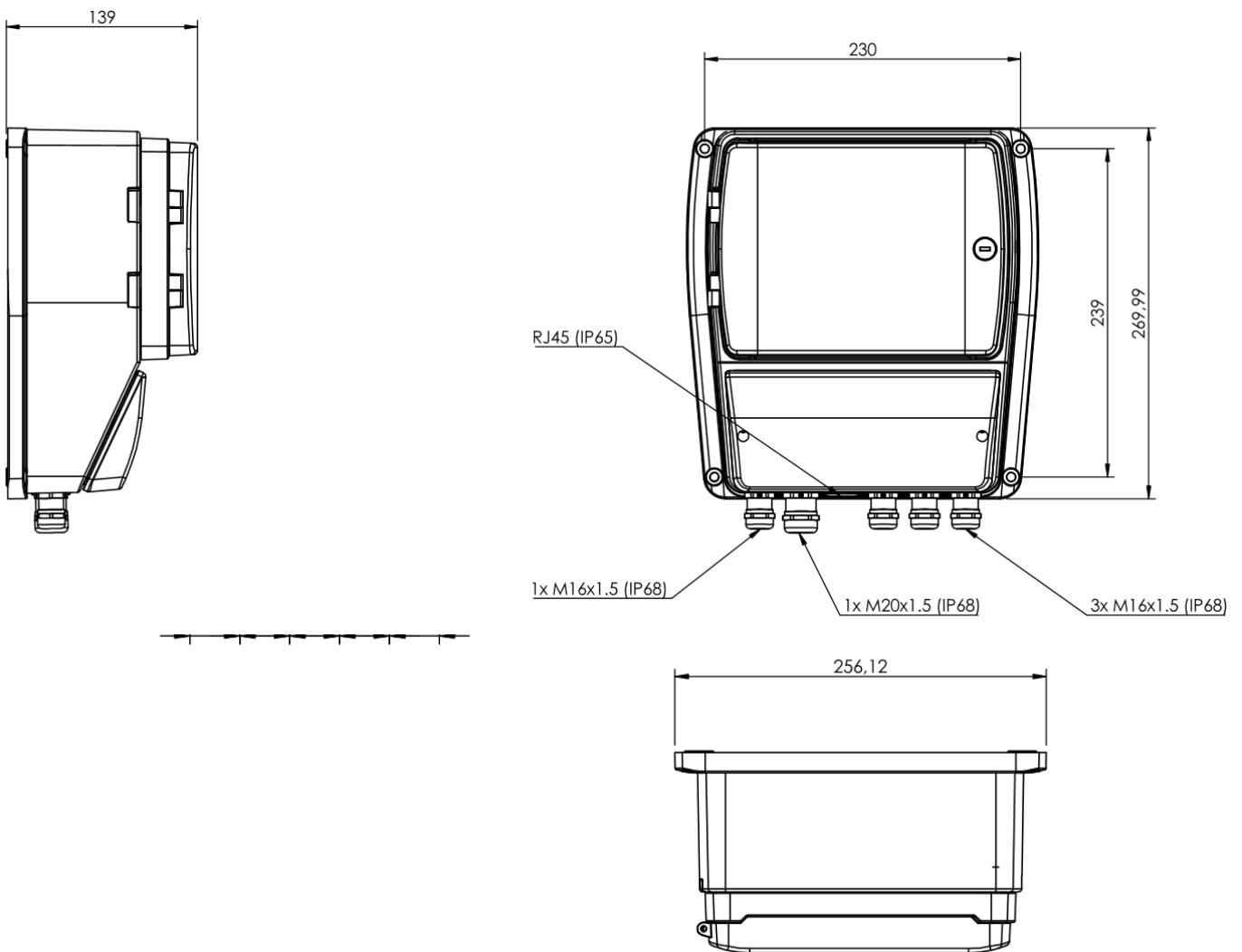

Contact details

Washington Business Park, Turbine
Way, Washington, SR5 3NZ

Phone	0191 5131313
E-mail	hello@siris.co.uk
Web	siris.co.uk